

ATLANTIC VERSION TERMINATOR INTERFACE ADAPTER	PART NUMBER	REVISION	DESCRIPTION	FEED TYPE	APPLICATOR STYLE CONVERSION CHART						
					CONVERT TO	PART NUMBERS REQUIRED					
	2151687-1	A	FINE CRIMP HEIGHT ADJUST	MECHANICAL	PNEUMATIC FEED	2119950-1	1338685-1	5-18022-5	2119641-1	2119799-1	2063440-1
					SERVO LATCH PLATE	2119951-1	-	8-2151687-5	1901094-3	-	2168400-6 (QUANTITY 2)
					SMART APPLICATOR	2161326-1	-	8-2151687-4	-	-	-
	2151687-2	A	FINE CRIMP HEIGHT ADJUST	PNEUMATIC	MECHANICAL FEED	2119949-1	1338685-1	5-18022-5	2119653-1	-	-
					SERVO LATCH PLATE	2119951-1	-	8-2151687-5	1901094-3	-	2168400-6 (QUANTITY 2)
					SMART APPLICATOR	2161326-1	-	8-2151687-4	-	-	-
	2151687-5	A	FINE CRIMP HEIGHT ADJUST	SERVO LATCH PLATE ⁴	MECHANICAL FEED	2119949-1	1338685-1	5-18022-5	2119653-1	-	-
PNEUMATIC FEED					2119950-1	1338685-1	5-18022-5	2119641-1	2119799-1	2063440-1	
2151687-6	A	NON-CRIMP HEIGHT ADJUST	SERVO LATCH PLATE ⁴	-	-	-	-	-	-	-	
				-	-	-	-	-	-	-	
2151687-7	A	FINE CRIMP HEIGHT ADJUST	NONE	-	-	-	-	-	-	-	
				-	-	-	-	-	-	-	
7-2151687-7	A	CRIMP TOOLING KIT	-	-	-	-	-	-	-	-	

APPLICATOR DATA		
CRIMP	SIZE	TYPE
WIRE	4.70 mm [.185]	F
INSUL	6.10 mm [.240]	F
APPLICATOR INSTRUCTIONS 408-10389		

TERMINAL DATA: LEAR TERMINAL		TE CRIMP SPECIFICATION	
TERMINAL NAME: CLAW TERMINAL WITH NUT			
WIRE STRIP LENGTH		INSULATION DIAMETER RANGE	
4.85-5.57 mm [.191-.219 IN]		Ø0.00-4.70 mm [.000-.185 IN]	
TERMINAL APPLICATION SPECIFICATION	NONE	-	-
TERMINALS APPLIED			
TE TERMINAL	LEAR TERMINAL	TE TERMINAL	LEAR TERMINAL
2142386-1	25020.212.179		

WIRE SIZE	CRIMP HEIGHT mm [INCH]	CRIMP HEIGHT REFERENCE SETTING
6.00mm2	3.42+/-0.05 [1.35+/- .002]	6.8
5.00mm2	3.24+/-0.05 [1.28+/- .002]	8.8
4.00mm2	3.07+/-0.05 [1.21+/- .002]	10.5
3.00mm2	2.89+/-0.05 [1.14+/- .002]	12.6

- ¹ RECOMMENDED SPARE PARTS
- ² GREASE BEARING SURFACES LIGHTLY
- 3. LUBRICATE DAILY PER THE APPLICATOR INSTRUCTION SHEET SUPPLIED WITH THE APPLICATOR.
- ⁴ APPLICATOR SPECIFIC DATA TO BE ENTERED INTO BLANK MEMORY CHIP AT ASSEMBLY. SEE BELOW FOR PART NUMBER:
 - MECHANICAL FEED WITH "SMART APPLICATOR" CONVERSION: 8-2151687-4
 - PNEUMATIC FEED WITH "SMART APPLICATOR" CONVERSION: 8-2151687-4
 - SERVO FEED WITH "FINE CRIMP HEIGHT ADJUST": 8-2151687-5
 - SERVO FEED WITH "NON-CRIMP HEIGHT ADJUST": 8-2151687-6
- 5. ADJUSTMENT OF THE STRIPPER MAY BE REQUIRED WHEN MOVING THE APPLICATOR BETWEEN BENCH AND LEADMAKER APPLICATIONS.
- ⁶ APPLY PART NUMBER 1-23419-5 LOCTITE TO THREADS OF ITEM 50.
- ⁷ GREASE THREADS, GROOVE AND O-RING ON ITEMS 35 & 252.
- ⁸ MAGNET, ITEM 166 MUST BE ORIENTED CORRECTLY IN ORDER TO PROPERLY ACTUATE THE COUNTER.
- ⁹ CRIMP HEIGHT REFERENCE SETTING WAS THE SETTING USED WHEN THE APPLICATOR WAS QUALIFIED AT THE FACTORY. ADJUSTMENT MAY BE NECESSARY WHEN RUNNING APPLICATOR IN THE FIELD.
- ¹⁰ SPARE FEED CAM STORAGE LOCATION REFER TO INSTRUCTION SHEET FOR ADDITIONAL INFORMATION.
- ¹¹ TO CONVERT THE APPLICATOR TO A NON-CARRIER CUTTING STYLE, REMOVE ITEM 13 AND ATTACH TO THE LOCATION ON THE BACK SIDE OF THE HOUSING. REFER TO INSTRUCTION SHEET FOR ADDITIONAL INFORMATION.
- ¹² WHEN ASSEMBLING -6 NON-CRIMP HEIGHT ADJUST APPLICATOR USE SHIM PACK 2119957-2 TO ALIGN APPLICATOR'S MAXIMUM WIRE CRIMP HEIGHT AT NORMAL TERMINATOR SHUT HEIGHT
- 13. TERMINAL LUBRICANT IS RECOMMENDED.

***WARNING**
ON INSTALLATION, SET WIRE DISC, ITEM 40 TO LARGEST WIRE SIZE SETTING. USE OF SETTINGS BELOW MINIMUM REQUIRED CRIMP HEIGHT SETTING WILL CAUSE DAMAGE TO CRIMP TOOLING.

-77	-7	-6	-5	-2	-1	PART NO	DESCRIPTION	ITEM NO
-	-	1	-	-	-	2119957-2	APPLICATOR SHIM PACK	260
-	1	-	1	1	1	8-21084-0	O-RING, .676 ID, .070 DIA. MAT.	252
-	-	-	-	1	-	2119640-1	PUSH ROD, AIR FEED	250
-	-	-	-	1	-	2079988-1	BUSHING, LCH5-12, MISUMI	249
-	-	-	-	1	-	2119641-1	FEED CAM, AIR FEED	248
-	1	-	1	1	1	2119798-1	DETENT PIN	247

ATLANTIC VERSION
Shown on sheets 1 of 4 & 2 of 4
(Pacific version shown on sheets 3 of 4 & 4 of 4)

SET UP GAUGE	LOC	DIST	REVISIONS					
2119599-1	A	66	P	LTN	DESCRIPTION	DATE	OWN	APVD
			1		ORIGINAL	17JUL2012	BH	BH
			A		RELEASED	02OCT2012	BH	BH

-	1	-	1	1	1	1-22279-3	SPRING, COMPRESSION	246
-	-	1	-	-	-	2161314-1	RAM, STEPPED, AMP STYLE, SIDE FEED	245
-	1	1	1	1	1	2119082-9	CAM, SNAIL, INSULATION ADJUSTMENT	244
-	1	1	1	1	1	2079764-1	WASHER, WAVE SPRING, CREST-TO-CREST	243
-	1	1	1	1	1	2119083-1	RETAINER, INSULATION DIAL	242
-	1	1	1	1	1	7-18023-7	SCR, SKT HD CAP M3 X 4.0	241
-	-	2	2	-	-	2168400-6	SHCS, LOW HEAD, RoHS, M5 X 16	240
-	-	-	-	-	1	2119580-1	MECHANICAL FEED ASSEMBLY	239
-	-	-	-	-	1	2063440-1	AIR FEED MODULE	238
-	-	1	1	-	-	2119740-2	TAG, IDENTIFICATION	213
-	-	1	1	-	-	1901094-3	SPACER, FEEDER	198
-	1	1	1	1	1	993111-8	PIN, SLOTTED SPRING 3.0 X 12.0	177
-	1	1	1	1	1	8-22280-7	SPRING, COMPRESSION	176
-	1	1	1	1	1	1752353-2	GUIDE PIN, HOLDDOWN	175
-	1	1	1	1	1	1901680-2	GUIDE PIN, HOLDDOWN	174
-	-	-	-	2	-	21045-3	RING, RETAIN, EXTERN, 3/16 CRESCENT	172
-	1	1	1	1	1	994969-1	MAGNET, RARE EARTH HIGH ENERGY	166
-	REF	REF	REF	REF	REF	994970-2	COUNTER, MAGNETIC	164
-	-	-	-	1	-	240638-1	SPRING, FEED FINGER	163
-	-	-	-	1	-	3-23627-7	PIN, RETAIN, GRVD, 3/16 X .854	137
-	-	-	-	1	-	2119799-1	HOLDER, FEED FINGER, AF	136
-	-	REF	REF	-	-	SEE NOTE 4	MEMORY CHIP, PROGRAMMED	135
-	-	1	1	-	-	1633743-1	SERVO FEED LATCH ASM	133
-	1	1	1	1	1	318563-1	GUARD, FRONT CHIP	119
-	-	REF	REF	-	-	2119944-1	FEED FINGER ASSEMBLY, SF	117
-	1	1	1	1	1	2119955-1	ASSY, LUBRICATOR, SIDE FEED	113
-	1	1	1	1	1	2-455888-8	SPACER, CRIMPER	82
-	1	1	1	1	1	22278-8	SPRING, COMPRESSION	77
-	1	1	1	1	1	854769-4	HOLDER, INS	74
-	1	1	1	1	1	2119956-1	DOCUMENTATION PACKAGE	71
-	1	-	-	1	1	2119740-1	TAG, IDENTIFICATION	67
-	2	2	2	2	2	2168078-1	SCREW, DRIVE, RH, RoHS	66
-	1	-	1	1	1	2119793-1	LIMITER, ADJUSTMENT BOLT	63
-	3	-	3	3	3	992763-5	SCR, SET, SOC, CONE POINT, M3 x 4.0	62
-	1	1	1	1	1	2079383-4	SCR, BHSC, RoHS (M4 X 8)	60
-	-	-	-	1	1	5-18022-5	SCR, HEX HD CAP, M4 X 6.0	59
-	1	1	1	1	1	21028-2	PIN, SLOTTED SPRING .062 X .250	58
-	-	-	-	1	1	1338685-1	PAWL, FEED	56
-	4	4	4	4	4	2168400-1	SHCS, LOW HEAD, RoHS, M4 X 12	54
-	1	1	1	1	1	1-5018030-0	NUT, HEX, REG, RoHS, M3.5	52
-	1	1	1	1	1	1901681-2	HOLDDOWN, TERMINAL	51
-	1	1	1	1	1	2-1752354-2	STANDOFF, HOLD-DOWN	50
-	-	-	-	1	2	18023-9	SCR, SKT HD CAP M4 X 6.0	49
-	-	-	-	-	1	2119652-1	FEED CAM, PRE FEED	48
-	-	-	-	-	1	2119653-1	FEED CAM, POST FEED	47
-	1	1	1	1	1	2119656-9	APPLICATOR BASIC ASSEMBLY, SF	46
-	1	-	1	1	1	2161311-1	RAM, STEPPED, AMP STYLE, SIDE FEED	44
-	1	1	1	1	1	1-2079383-5	SCR, BHSC, RoHS (M8 X 40)	41
-	1	-	1	1	1	2119645-1	DISC, NUMBERED FA WIRE ADJUSTMENT	40
-	1	-	1	1	1	2119957-1	APPLICATOR SHIM PACK	39
-	1	1	1	1	1	2119644-5	RAM WASHER, PRECISION	38
-	1	1	1	1	1	2119085-1	FA HEAD, ATLANTIC STYLE	37
-	1	-	1	1	1	2119092-1	BOLT, ADJUSTMENT	35
-	1	1	1	1	1	1752356-6	SUPPORT, TERMINAL	34
-	1	1	1	1	1	2161328-1	HEX HEAD, FLANGED, M5 x 8mm LONG	32
-	1	1	1	1	1	2119959-2	ASSEMBLY, STRIP GUIDE	29
-	1	1	1	1	1	1-455888-0	SPACER, CRIMPER	28
-	1	1	1	1	1	2168083-2	SCR, SKT HD CAP, RoHS, M4 X 8.0	21
-	1	1	1	1	1	1-18028-2	WASHER, FLAT, REG M4	20
-	1	1	1	1	1	2119533-1	STRIPPER, SIDE FEED	19
-	1	1	1	1	1	2119806-1	INSERT, SHEAR	13
-	1	1	1	1	1	3-22280-3	SPRING, COMPRESSION	12
-	1	1	1	1	1	1-356885-3	STOP, SHEAR	11
-	1	1	1	1	1	2119805-1	SHEAR HOLDER, FRONT	10
-	1	1	1	1	1	454276-5	FLOATING SHEAR, FRONT	9
-	1	1	1	1	1	1-1633927-5	ANVIL, COMBINATION	8
-	-	-	-	-	-	-	-	7
-	-	-	-	-	-	-	-	6
-	1	1	1	1	1	2119780-9	DEPRESSOR, SHEAR	5
-	1	1	1	1	1	238011-2	BLOCK, CRIMPER SPACER	4
-	1	1	1	1	1	1-2119582-6	CRIMPER, INSULATION F PREMIUM	3
-	1	1	1	1	1	2-455888-1	SPACER, CRIMPER	2
-	1	1	1	1	1	4-1633738-4	CRIMPER, WIRE	1
-77	-7	-6	-5	-2	-1	PART NO	DESCRIPTION	ITEM NO

DIMENSIONS:		TOLERANCES UNLESS OTHERWISE SPECIFIED:		OWN: BOB HIGMAN 17JUL2012		TE Connectivity Harrisburg, PA 17105-3608	
mm		0 PLC ±.1 1 PLC ±0.1 2 PLC ±0.02 3 PLC ±0.005 4 PLC ±0.0005 ANGLES ±.1		CHK: G. BAILEY 17JUL2012		NAME: Ocean Side Feed Applicator	
		FINISH:		APVD: M. CLIFFORD 17JUL2012		SIZE: A1 CAGE CODE: 00779 DRAWING NO: C-2151687	
MATERIAL:		FINISH:		WEIGHT:		RESTRICTED TO:	
Customer Accessible Production Drawing				SCALE: 1:1		SHEET 1 of 4 REV A	

LOC		DIST		REVISIONS			
A	66	P	LTM	DESCRIPTION	DATE	OWN	APVD
		-	-	SEE SHEET 1	-	-	-

FEED TYPE MECHANICAL

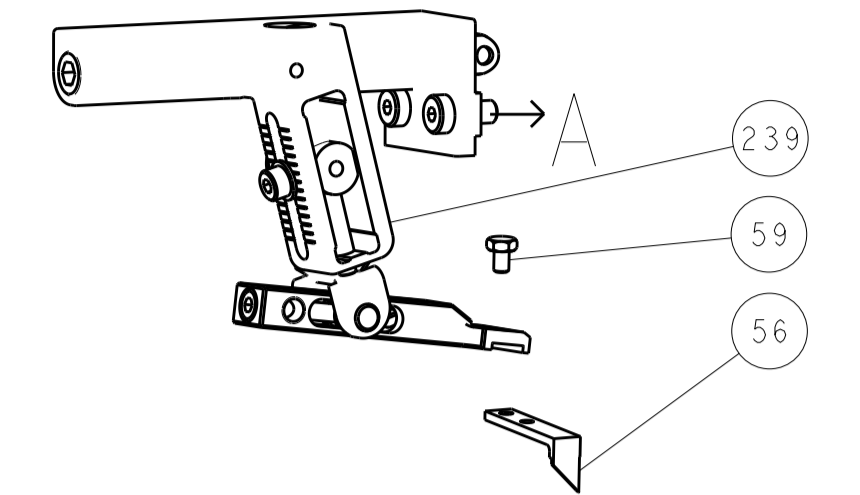

PNEUMATIC

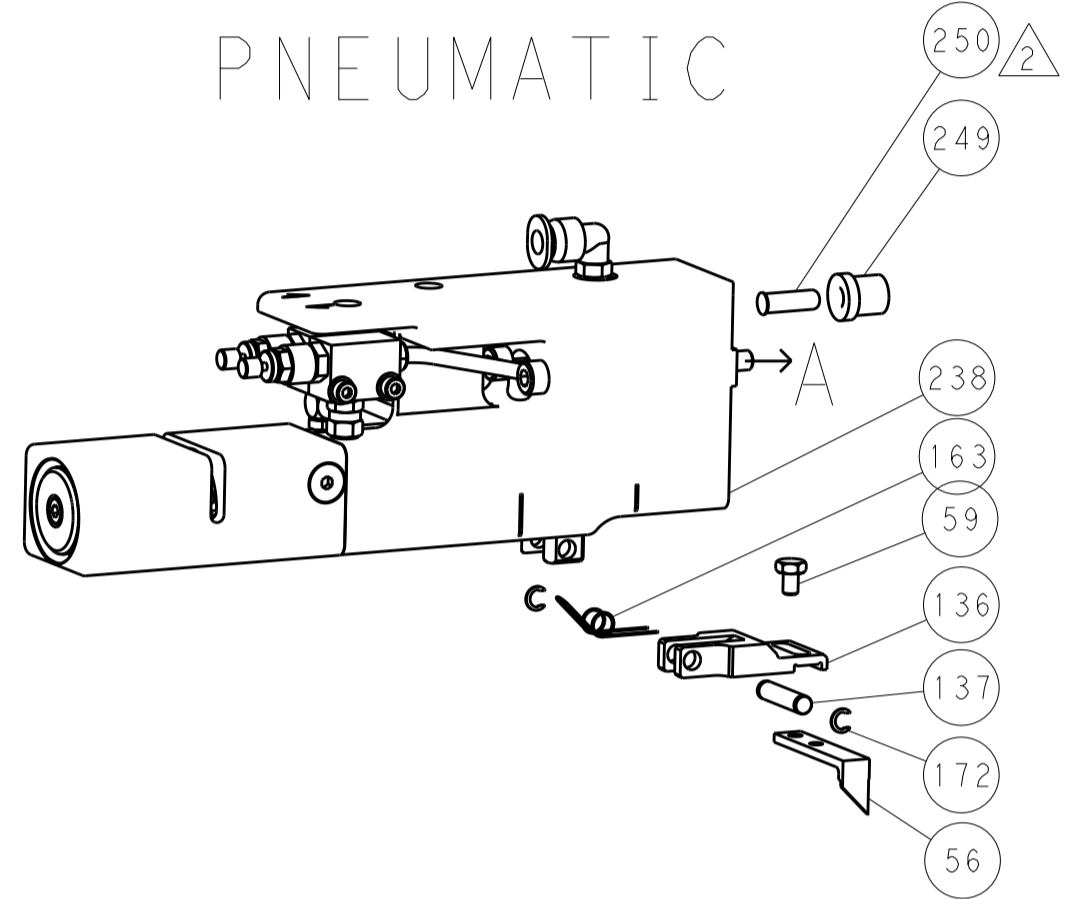

SERVO LATCH PLATE

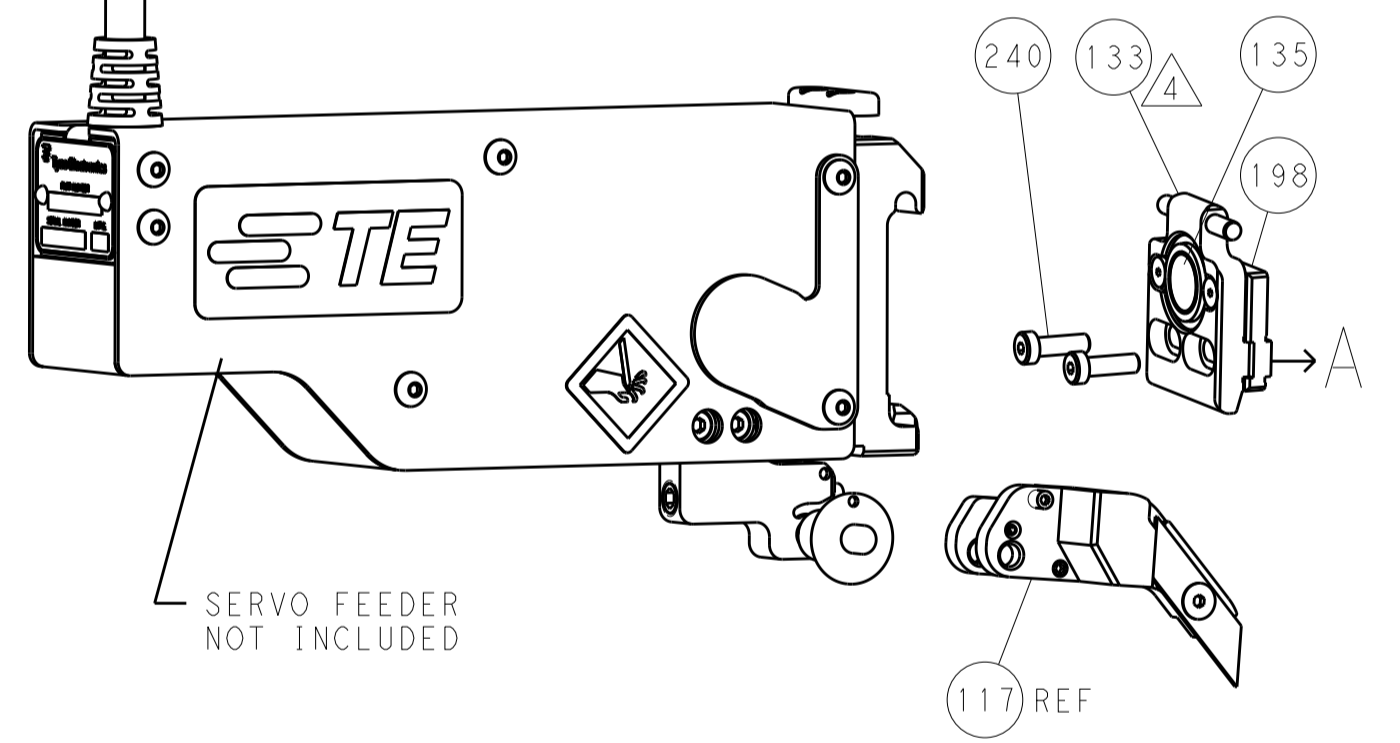

CAM POSITIONS

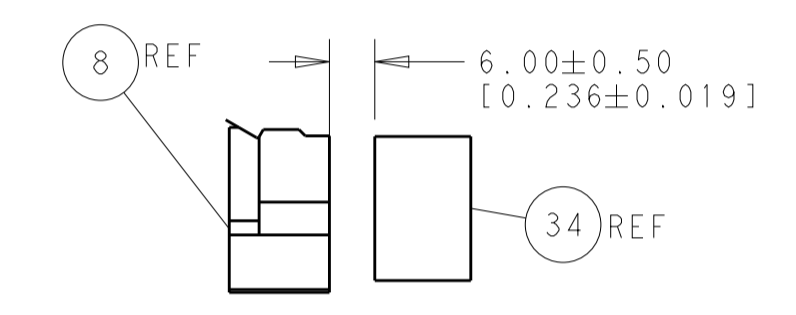
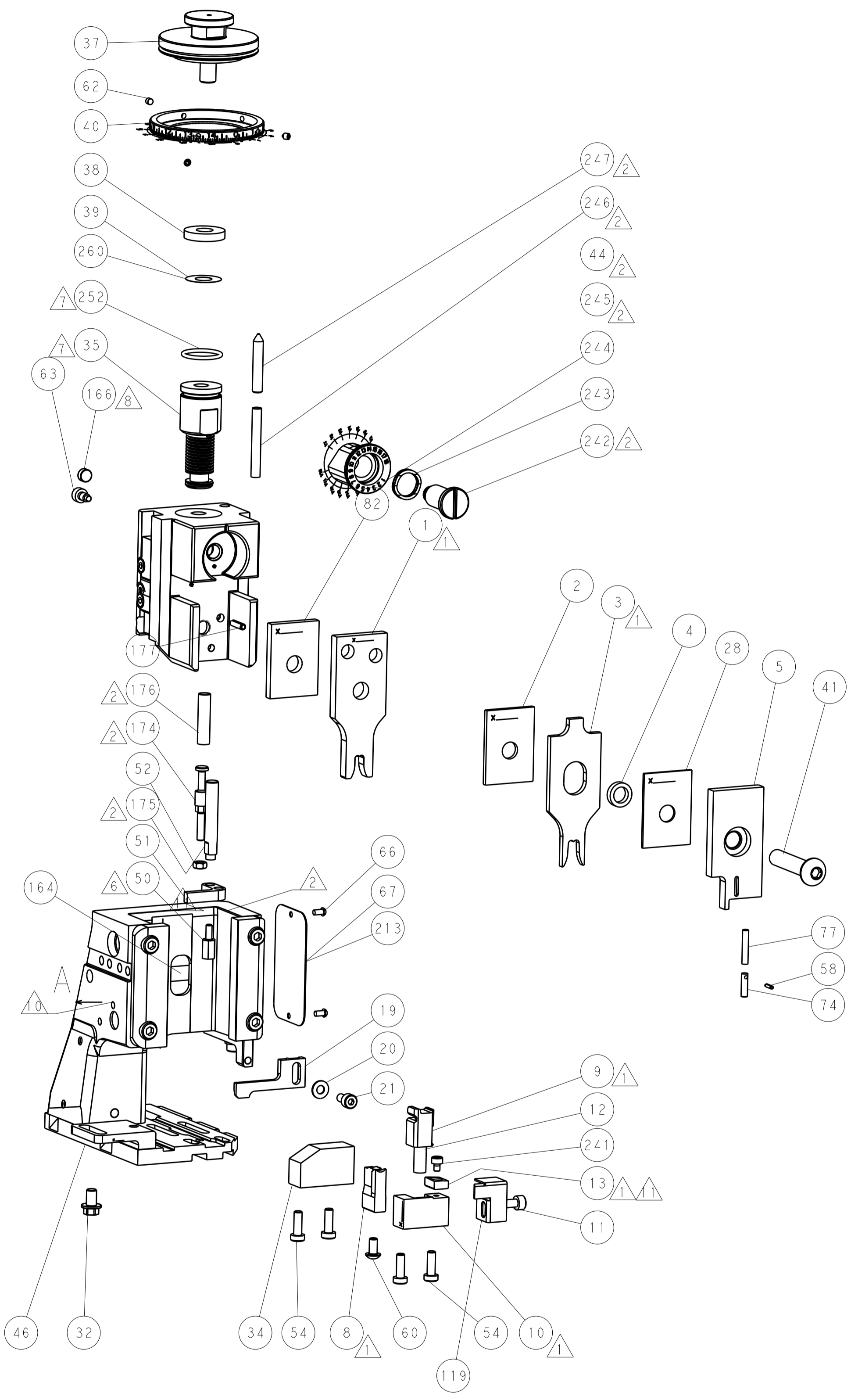
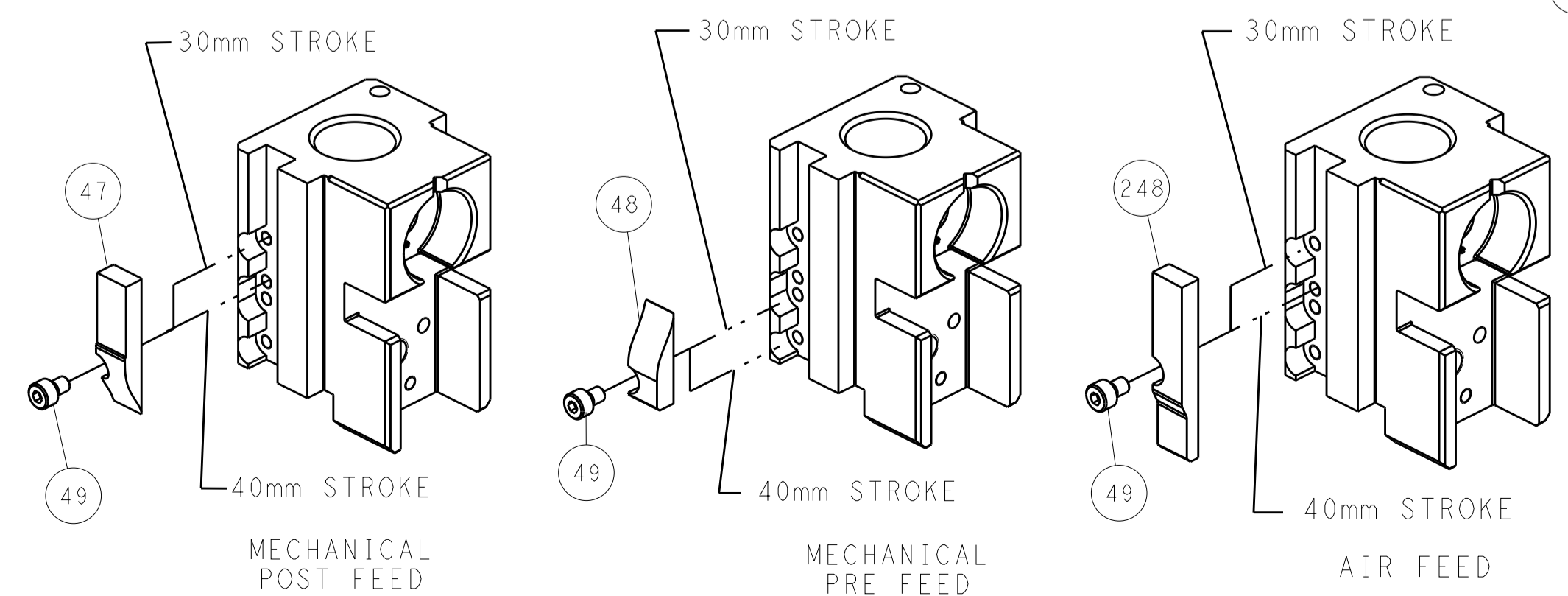

TERMINAL SUPPORT LOCATION

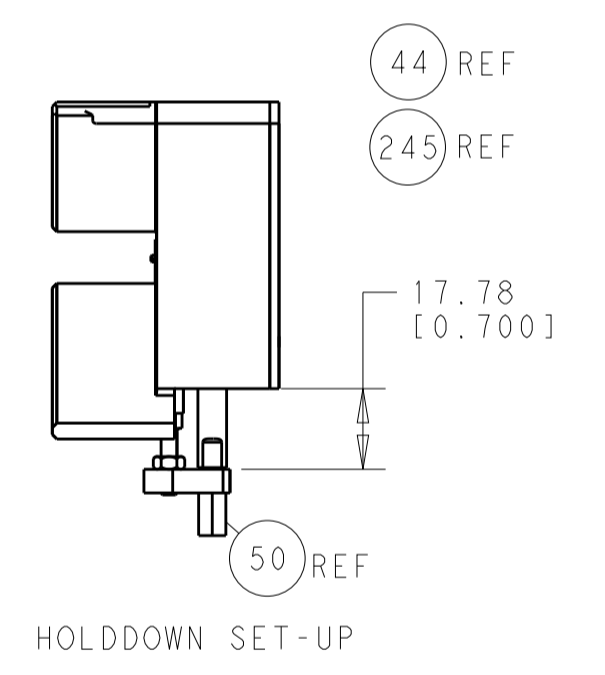

HOLDDOWN SET-UP

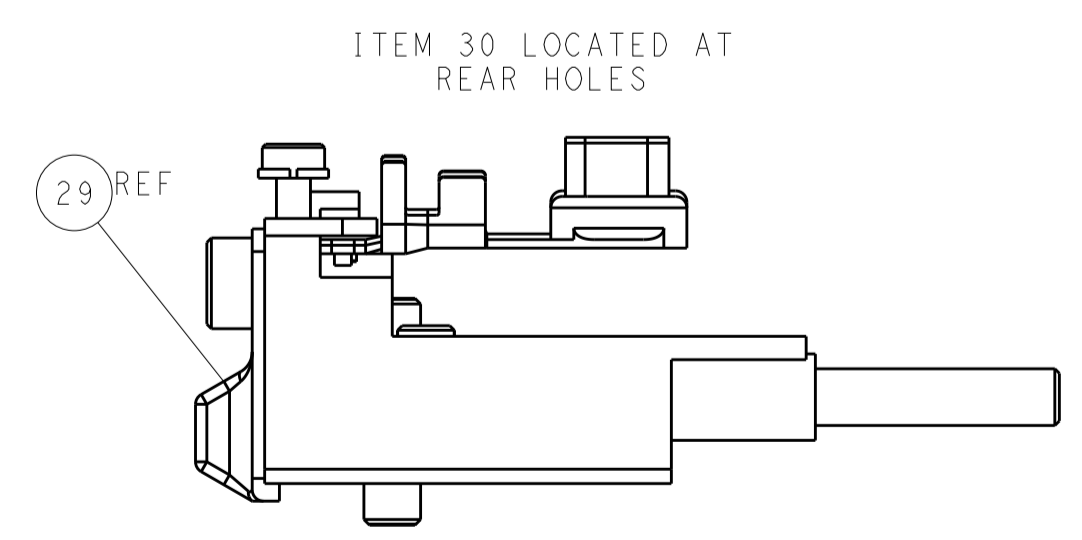

FEED TRACK POSITION GUIDE BY INSULATION BARREL

ATLANTIC VERSION
 Shown on sheets 1 of 4 & 2 of 4
 (Pacific version shown on sheets 3 of 4 & 4 of 4)

DIMENSIONS:		TOLERANCES UNLESS OTHERWISE SPECIFIED:		OWN: BOB HIGMAN 17JUL2012		TE Connectivity	
mm	0 PLC ±0.1	1 PLC ±0.1	2 PLC ±0.02	3 PLC ±0.005	4 PLC ±0.0005	5 ANGLES ±0.0005	Harrisburg, PA 17105-3608
MATERIAL:		FINISH:		APVD: G. BAILEY 17JUL2012		NAME: Ocean Side Feed Applicator	
Customer Accessible Production Drawing		SCALE: 1:1		SHEET: 2 of 4		REV: A	

PACIFIC VERSION TERMINATOR INTERFACE ADAPTER	PART NUMBER	REVISION	DESCRIPTION	FEED TYPE	APPLICATOR STYLE CONVERSION CHART						
					CONVERT TO	PART NUMBERS REQUIRED					
	2-2151687-1	A	FINE CRIMP HEIGHT ADJUST	MECHANICAL	PNEUMATIC FEED	2119950-1	1338685-1	5-18022-5	2119641-2	2119799-1	2063440-1
					SERVO LATCH PLATE	2119951-1	-	8-2151687-5	1901094-3	-	2168400-6 (QUANTITY 2)
	2-2151687-2	A	FINE CRIMP HEIGHT ADJUST	PNEUMATIC	MECHANICAL FEED	2119949-1	1338685-1	5-18022-5	2119653-2	-	-
					SERVO LATCH PLATE	2119951-1	-	8-2151687-5	1901094-3	-	2168400-6 (QUANTITY 2)
	2-2151687-5	A	FINE CRIMP HEIGHT ADJUST	SERVO LATCH PLATE ⁴	MECHANICAL FEED	2119949-1	1338685-1	5-18022-5	2119653-2	-	-
	2-2151687-7	A	FINE CRIMP HEIGHT ADJUST	NONE	PNEUMATIC FEED	2119950-1	1338685-1	5-18022-5	2119641-2	2119799-1	2063440-1
	7-2151687-7	A	CRIMP TOOLING KIT	-	-	-	-	-	-	-	-

APPLICATOR DATA		
CRIMP WIRE	SIZE	TYPE
	4.70 mm [.185]	F
INSUL	6.10 mm [.240]	F
APPLICATOR INSTRUCTIONS 408-10389		

TERMINAL DATA: LEAR TERMINAL		TE CRIMP SPECIFICATION	
TERMINAL NAME: CLAW TERMINAL WITH NUT			
WIRE STRIP LENGTH		INSULATION DIAMETER RANGE	
4.85-5.57 mm [.191-.219 IN]		Ø0.00-4.70 mm [.000-.185 IN]	
TERMINAL APPLICATION SPECIFICATION	NONE		
TERMINALS APPLIED			
TE TERMINAL	LEAR TERMINAL	TE TERMINAL	LEAR TERMINAL
2142386-1	25020.212.179		

WIRE SIZE	CRIMP HEIGHT mm [INCH]	CRIMP HEIGHT REFERENCE SETTING
6.00mm2	3.42 +/- 0.05 [.135 +/- .002]	6.8
5.00mm2	3.24 +/- 0.05 [.128 +/- .002]	8.8
4.00mm2	3.07 +/- 0.05 [.121 +/- .002]	10.5
3.00mm2	2.89 +/- 0.05 [.114 +/- .002]	12.6

- RECOMMENDED SPARE PARTS
- GREASE BEARING SURFACES LIGHTLY
- 3. LUBRICATE DAILY PER THE APPLICATOR INSTRUCTION SHEET SUPPLIED WITH THE APPLICATOR.
- APPLICATOR SPECIFIC DATA TO BE ENTERED INTO BLANK MEMORY CHIP AT ASSEMBLY. SEE BELOW FOR PART NUMBER:
 MECHANICAL FEED WITH "SMART APPLICATOR" CONVERSION: 8-2151687-4
 PNEUMATIC FEED WITH "SMART APPLICATOR" CONVERSION: 8-2151687-4
 SERVO FEED WITH "FINE CRIMP HEIGHT ADJUST": 8-2151687-5
- 5. ADJUSTMENT OF THE STRIPPER MAY BE REQUIRED WHEN MOVING THE APPLICATOR BETWEEN BENCH AND LEADMAKER APPLICATIONS.
- APPLY PART NUMBER 1-23419-5 LOCTITE TO THREADS OF ITEM 50.
- GREASE THREADS, GROOVE AND O-RING ON ITEMS 139 & 152.
- MAGNET MUST BE ORIENTED CORRECTLY IN ORDER TO PROPERLY ACTUATE THE COUNTER.
- CRIMP HEIGHT REFERENCE SETTING WAS THE SETTING USED WHEN THE APPLICATOR WAS QUALIFIED AT THE FACTORY. ADJUSTMENT MAY BE NECESSARY WHEN RUNNING APPLICATOR IN THE FIELD.
- SPARE FEED CAM STORAGE LOCATION REFER TO INSTRUCTION SHEET FOR ADDITIONAL INFORMATION.
- TO CONVERT THE APPLICATOR TO A NON-CARRIER CUTTING STYLE, REMOVE ITEM 13 AND ATTACH TO THE LOCATION ON BACK SIDE OF THE HOUSING. REFER TO INSTRUCTION SHEET FOR ADDITIONAL INFORMATION.
- 13. TERMINAL LUBRICANT IS RECOMMENDED.

***WARNING**
 ON INSTALLATION, SET WIRE DISC, ITEM 40 TO LARGEST WIRE SIZE SETTING. USE OF SETTINGS BELOW MINIMUM REQUIRED CRIMP HEIGHT SETTING WILL CAUSE DAMAGE TO CRIMP TOOLING.

-	1	1	1	1	2119782-1	FINE ADJUST HEAD ASM, PACIFIC STYLE	251
-	-	-	-	-	2119640-1	PUSH ROD, AIR FEED	250
-	-	-	-	-	2079988-1	BUSHING, LCH5-12, MISUMI	249
-	1	1	1	1	1-22279-3	SPRING, COMPRESSION	246
-77	-27	-25	-22	-21	PART NO	DESCRIPTION	ITEM NO

PACIFIC VERSION
 Shown on sheets 3 of 4 & 4 of 4
 (Atlantic version shown on sheets 1 of 4 & 2 of 4)

SET UP GAUGE	LOC	DIST	REVISIONS					
2119599-1	A	66	P	LTM	DESCRIPTION	DATE	OWN	APVD
			-	-	SEE SHEET 1			

-	1	1	1	1	2119082-9	CAM, SNAIL, INSULATION ADJUSTMENT	244
-	1	1	1	1	2079764-1	WASHER, WAVE SPRING, CREST-TO-CREST	243
-	1	1	1	1	2119083-1	RETAINER, INSULATION DIAL	242
-	1	1	1	1	7-18023-7	SCR, SKT HD CAP M3 X 4.0	241
-	-	2	-	-	2168400-6	SHCS, LOW HEAD, RoHS, M5 X 16	240
-	-	-	-	1	2119580-1	MECHANICAL FEED ASSEMBLY	239
-	-	-	-	1	2063440-1	AIR FEED MODULE	238
-	-	1	-	-	2119740-2	TAG, IDENTIFICATION	213
-	-	1	-	-	1901094-3	SPACER, FEEDER	198
-	1	1	1	1	993111-8	PIN, SLOTTED SPRING 3.0 X 12.0	177
-	1	1	1	1	8-22280-7	SPRING, COMPRESSION	176
-	1	1	1	1	1752353-2	GUIDE PIN, HOLDDOWN	175
-	1	1	1	1	1901680-2	GUIDE PIN, HOLDDOWN	174
-	-	-	-	2	21045-3	RING, RETAIN, EXTERN, 3/16 CRESCENT	172
-	1	1	1	1	994969-1	MAGNET, RARE EARTH HIGH ENERGY	166
-	REF	REF	REF	REF	994970-2	COUNTER, MAGNETIC	164
-	-	-	-	1	240638-1	SPRING, FEED FINGER	163
-	1	1	1	1	8-21084-1	O-RING, .801 ID, .070 DIA, MAT.	152
-	-	-	-	1	2119641-2	FEED CAM, AIR FEED	151
-	1	1	1	1	2119798-2	DETENT PIN	145
-	1	1	1	1	2079383-8	SCR, BHSC, RoHS (M4 X 16)	144
-	4	4	4	4	2168400-5	SHCS, LOW HEAD, RoHS, M4 X 20	143
-	-	-	-	1	2119653-2	FEED CAM, POST FEED	142
-	1	1	1	1	1-2119656-0	APPLICATOR BASIC ASSEMBLY, SF	141
-	1	1	1	1	2161312-1	RAM, STEPPED, ASIAN STYLE, SIDE FEED	140
-	1	1	1	1	2119092-2	BOLT, ADJUSTMENT	139
-	-	-	-	1	3-23627-7	PIN, RETAIN, GRVD, 3/16 X .854	137
-	-	-	-	1	2119799-1	HOLDER, FEED FINGER, AF	136
-	-	REF	-	-	SEE NOTE 4	MEMORY CHIP, PROGRAMMED	135
-	-	1	-	-	1633743-1	SERVO FEED LATCH ASM	133
-	1	1	1	1	318563-1	GUARD, FRONT CHIP	119
-	-	REF	-	-	2119944-1	FEED FINGER ASSEMBLY, SF	117
-	1	1	1	1	2119955-1	ASSY, LUBRICATOR, SIDE FEED	113
-	1	1	1	1	2-455888-8	SPACER, CRIMPER	82
-	1	1	1	1	22278-8	SPRING, COMPRESSION	77
-	1	1	1	1	854769-4	HOLDER, INS	74
-	1	1	1	1	2119956-1	DOCUMENTATION PACKAGE	71
-	1	-	-	1	2119740-1	TAG, IDENTIFICATION	67
-	2	2	2	2	2168078-1	SCREW, DRIVE, RH, RoHS	66
-	1	1	1	1	2119793-1	LIMITER, ADJUSTMENT BOLT	63
-	3	3	3	3	992763-5	SCR, SET, SOC, CONE POINT, M3 X 4.0	62
-	-	-	-	1	5-18022-5	SCR, HEX HD CAP, M4 X 6.0	59
-	1	1	1	1	21028-2	PIN, SLOTTED SPRING .062 X .250	58
-	-	-	-	1	1338685-1	PAWL, FEED	56
-	1	1	1	1	1-5018030-0	NUT, HEX, REG, RoHS, M3.5	52
-	1	1	1	1	1901681-2	HOLDDOWN, TERMINAL	51
-	1	1	1	1	2-1752354-2	STANDOFF, HOLD-DOWN	50
-	-	-	-	1	18023-9	SCR, SKT HD CAP M4 X 6.0	49
-	-	-	-	1	2119652-1	FEED CAM, PRE FEED	48
-	1	1	1	1	1-2079383-5	SCR, BHSC, RoHS (M8 X 40)	41
-	1	1	1	1	2119645-1	DISC, NUMBERED FA WIRE ADJUSTMENT	40
-	1	1	1	1	2119957-1	APPLICATOR SHIM PACK	39
-	1	1	1	1	2119644-5	RAM WASHER, PRECISION	38
-	1	1	1	1	1752356-6	SUPPORT, TERMINAL	34
-	1	1	1	1	2161328-1	HEX HEAD, FLANGED, M5 X 8mm LONG	32
-	1	1	1	1	2119959-2	ASSEMBLY, STRIP GUIDE	29
-	1	1	1	1	1-455888-0	SPACER, CRIMPER	28
-	1	1	1	1	2168083-2	SCR, SKT HD CAP, RoHS, M4 X 8.0	21
-	1	1	1	1	1-18028-2	WASHER, FLAT, REG M4	20
-	1	1	1	1	2119533-1	STRIPPER, SIDE FEED	19
-	1	1	1	1	2119806-1	INSERT, SHEAR	13
-	1	1	1	1	3-22280-3	SPRING, COMPRESSION	12
-	1	1	1	1	1-356885-3	STOP, SHEAR	11
-	1	1	1	1	2119805-1	SHEAR HOLDER, FRONT	10
-	1	1	1	1	454276-5	FLOATING SHEAR, FRONT	9
-	1	1	1	1	1-1633927-5	ANVIL, COMBINATION	8
-	-	-	-	-	-	-	7
-	-	-	-	-	-	-	6
-	1	1	1	1	2119780-9	DEPRESSOR, SHEAR	5
-	1	1	1	1	238011-2	BLOCK, CRIMPER SPACER	4
-	1	1	1	1	1-2119582-6	CRIMPER, INSULATION F PREMIUM	3
-	1	1	1	1	2-455888-1	SPACER, CRIMPER	2
-	1	1	1	1	4-1633738-4	CRIMPER, WIRE	1
-77	-27	-25	-22	-21	PART NO	DESCRIPTION	ITEM NO

DIMENSIONS: mm		TOLERANCES UNLESS OTHERWISE SPECIFIED:		DWG: BOB HIGMAN 17JUL2012		CHK: G. BAILEY 17JUL2012		APVD: M. CLIFFORD 17JUL2012		NAME: Ocean Side Feed Applicator	
0 PLC ±.1		1 PLC ±0.1		2 PLC ±0.02		3 PLC ±0.005		4 PLC ±0.0005		SIZE: A	
MATERIAL: .		FINISH: .		WEIGHT: .		SCALE: 1:1		SHEET 3 OF 4		REV A	
Customer Accessible Production Drawing											

LOC		DIST		REVISIONS			
A	66	P	LTH	DESCRIPTION	DATE	OWN	APVD
		-		SEE SHEET 1			

FEED TYPE MECHANICAL

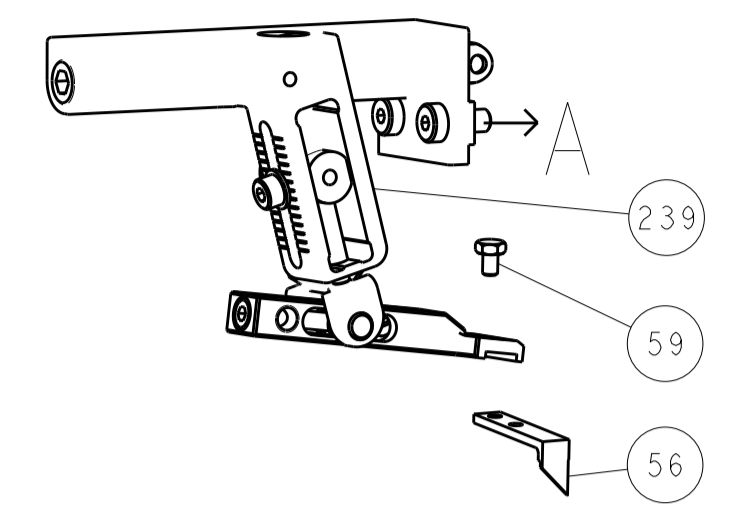

PNEUMATIC

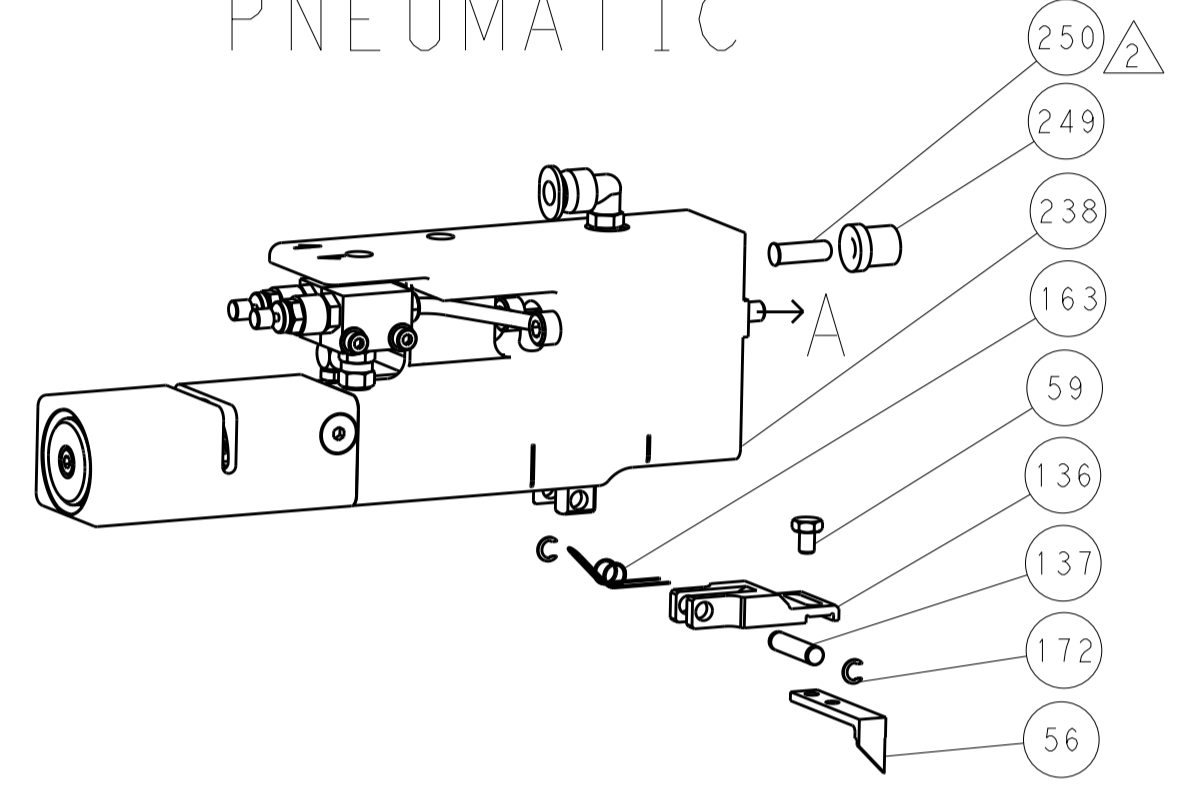

SERVO LATCH PLATE

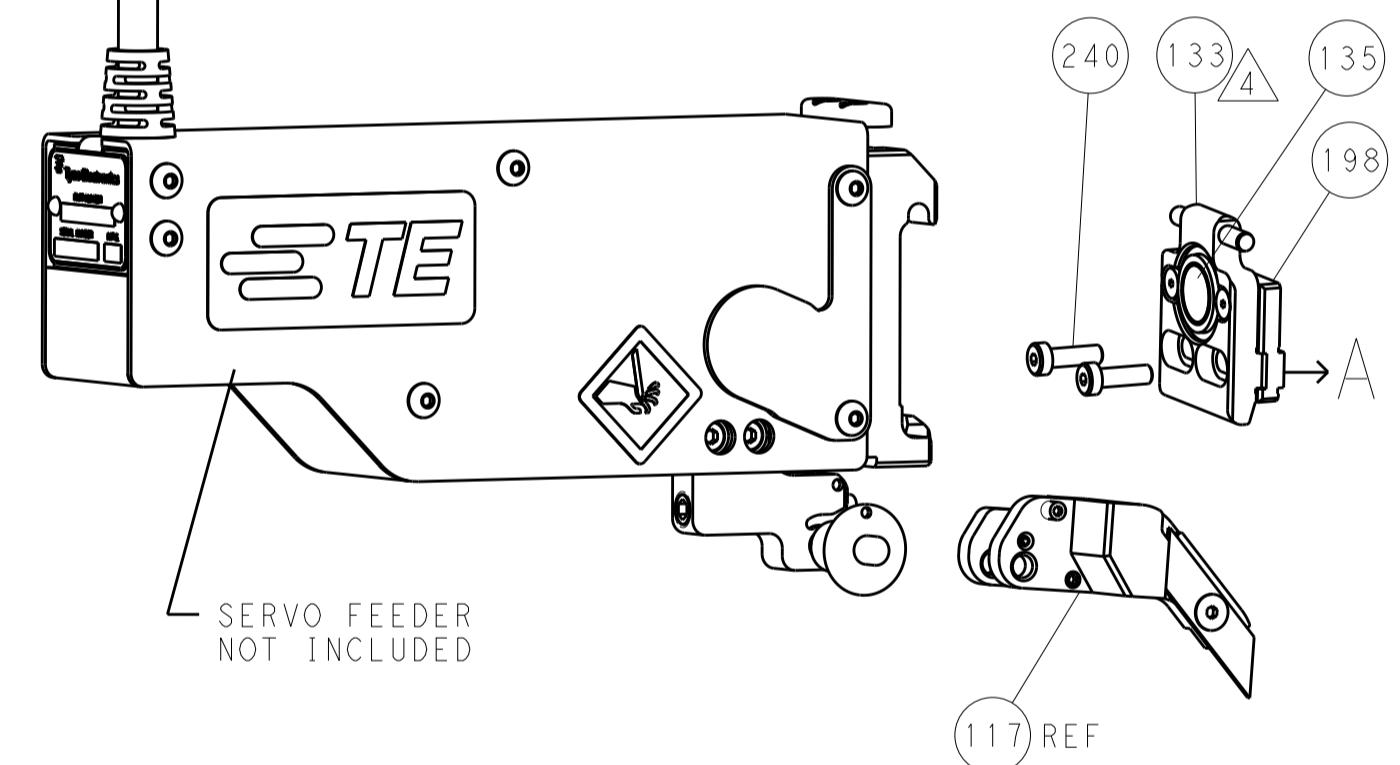

CAM POSITIONS

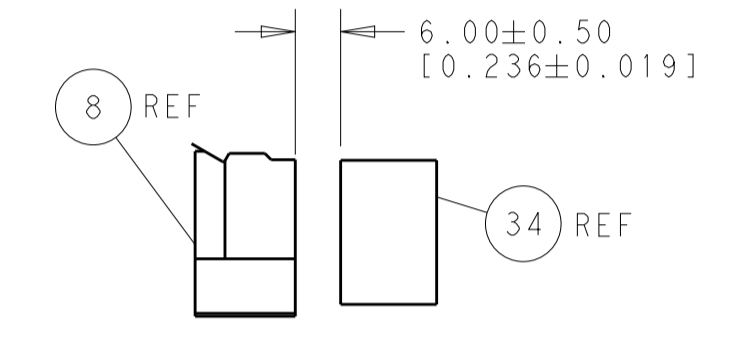
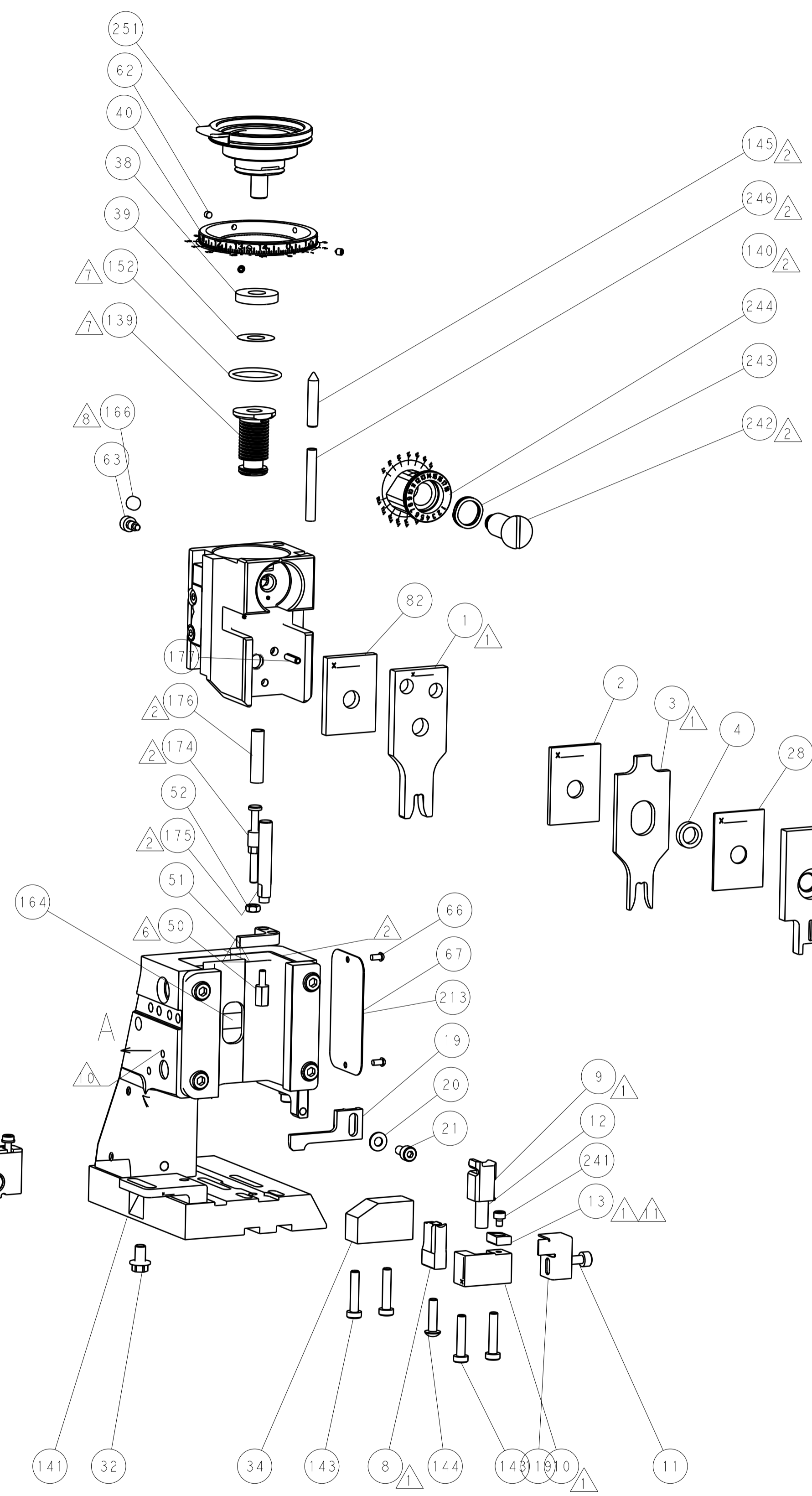
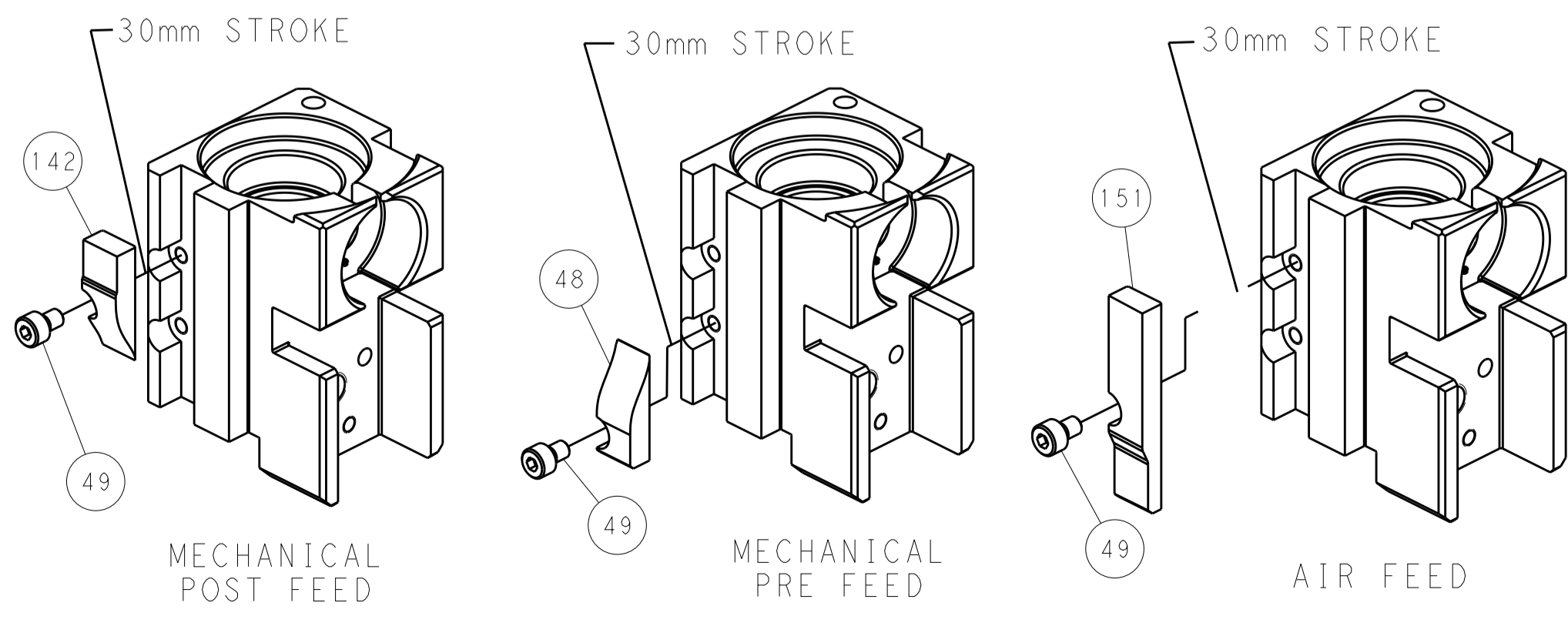

TERMINAL SUPPORT LOCATION

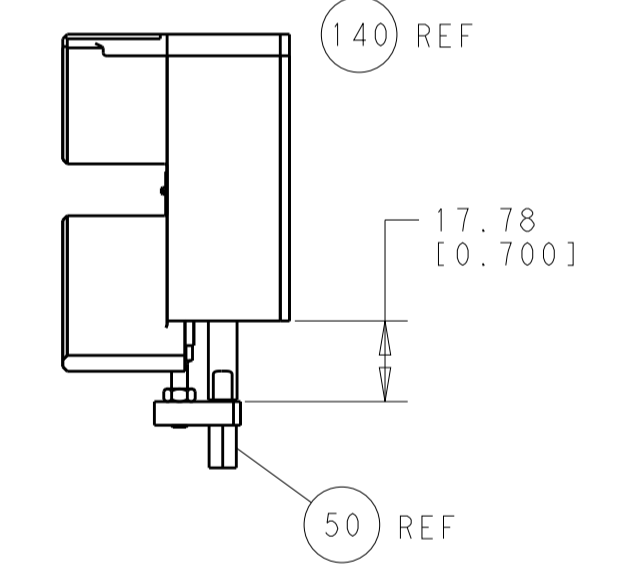

HOLDDOWN SET-UP

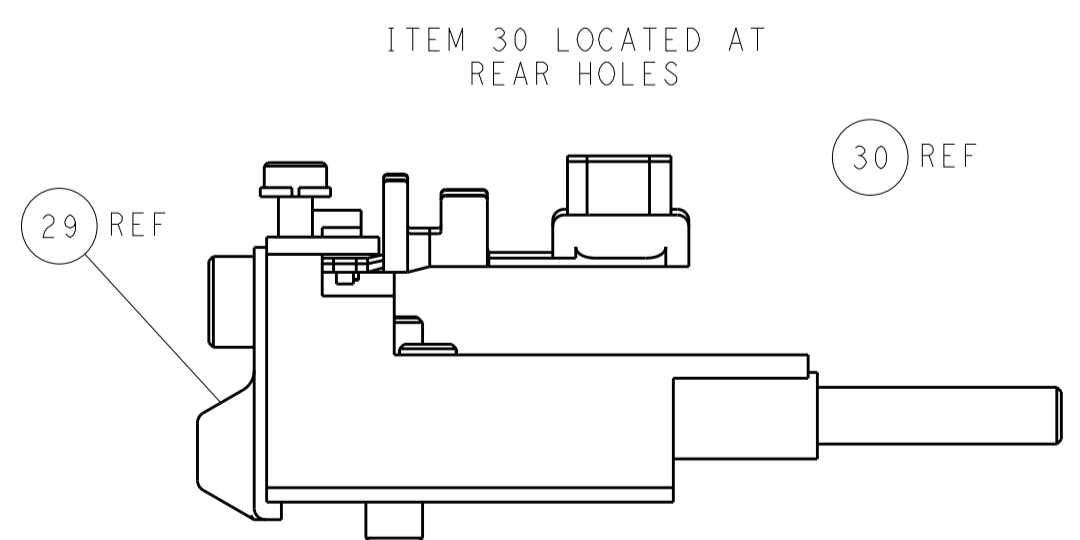

FEED TRACK POSITION GUIDE BY INSULATION BARREL

PACIFIC VERSION
 Shown on sheets 3 of 4 & 4 of 4
 (Atlantic version shown on sheets 1 of 4 & 2 of 4)

DIMENSIONS:		TOLERANCES UNLESS OTHERWISE SPECIFIED:		DWG: BOB HIGMAN 17JUL2012		TE Connectivity	
mm	0 PLC ±0.1	1 PLC ±0.1	2 PLC ±0.02	3 PLC ±0.005	4 PLC ±0.0005	ANGLES ±	Harrisburg, PA 17105-3608
MATERIAL:	FINISH:	WEIGHT:	SCALE:	SIZE:	CAGE CODE:	DRAWING NO:	RESTRICTED TO:
			1:1	A1	00779	©=2151687	
Customer Accessible Production Drawing				SHEET 4 OF 4 REV A			