

THIS DRAWING IS UNPUBLISHED. RELEASED FOR PUBLICATION
 © COPYRIGHT - By - ALL RIGHTS RESERVED.

LOC		DIST		REVISIONS			
P	LTR	DESCRIPTION		DATE	DWN	APVD	
	C2	REVISED PER ECR-18-006427		11MAY2018	BW	SV	

- 5 MTA PRODUCT SPEC IS 108-1051
MAG-MATE PRODUCT SPEC IS 108-2012
- 6 MAG-MATE APPLICATION SPEC IS 114-2046
MTA APPLICATION SPEC IS 114-1020
- 7 TERMINALS ARE STRESS RELIEVED

- 1 CONTINUOUS STRIP ON REELS WITH TERMINALS LOCATED ON 13.97±0.08 [.550±.003] CENTERS.
- 2 SLOT TERMINATES A SINGLE 0.8-0.9mm² [#18] AWG TIN PLATED SOLID, FUSED STRANDED OR STRANDED (7, 16, OR 19 STRANDS) WIRE WITH PET INSULATION, 2.03[.080] MAX DIA.
- 3 SLOT ACCEPTS 0.45-0.64mm [#25-#22] AWG COPPER MAGNET WIRE. SINGLE OR DOUBLE WIRE OF THE SAME SIZE AND TYPE. EXCEPT 0.64mm [#22] AWG WHICH IS FOR ONE WIRE ONLY.

ALUMINIUM RANGE IS 0.57-0.72mm [#23-#21] AWG SINGLE WIRE ONLY
ALUMINIUM WIRE RANGE IS APPLICABLE FOR POST TIN PLATED PART NOS ONLY.
- 4 SLOT ACCEPTS 0.54-0.81mm [#23.5-#20] AWG COPPER MAGNET WIRE. 2 WIRES OF THE SAME SIZE AND TYPE PER SLOT. EXCEPT 0.64-0.81 [#22-#20] AWG WHICH IS ONE WIRE ONLY.

ALUMINIUM RANGE IS 0.72-0.91mm [#21-#19] AWG SINGLE WIRE ONLY
ALUMINIUM WIRE RANGE IS APPLICABLE FOR POST TIN PLATED PART NOS ONLY.

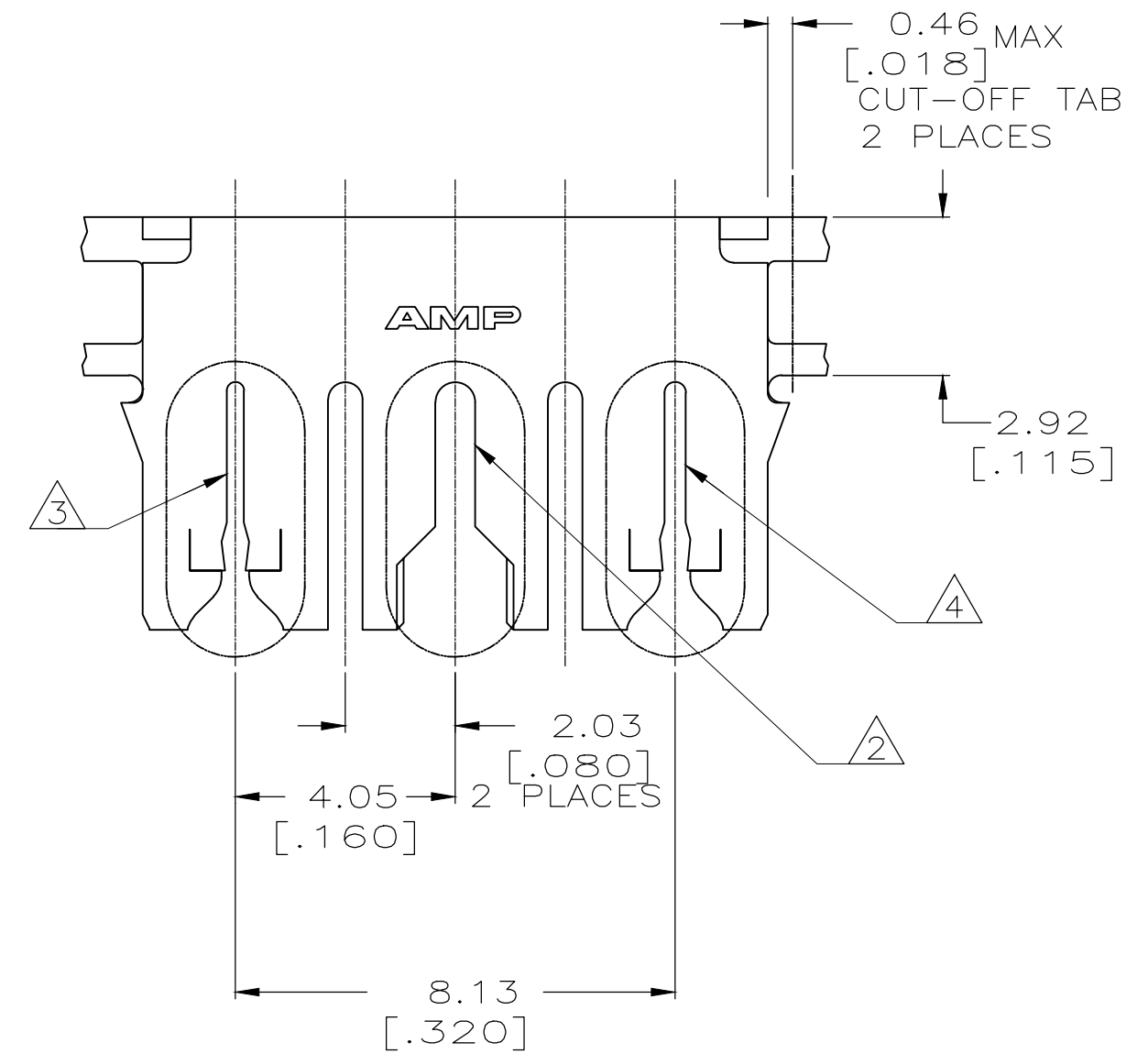
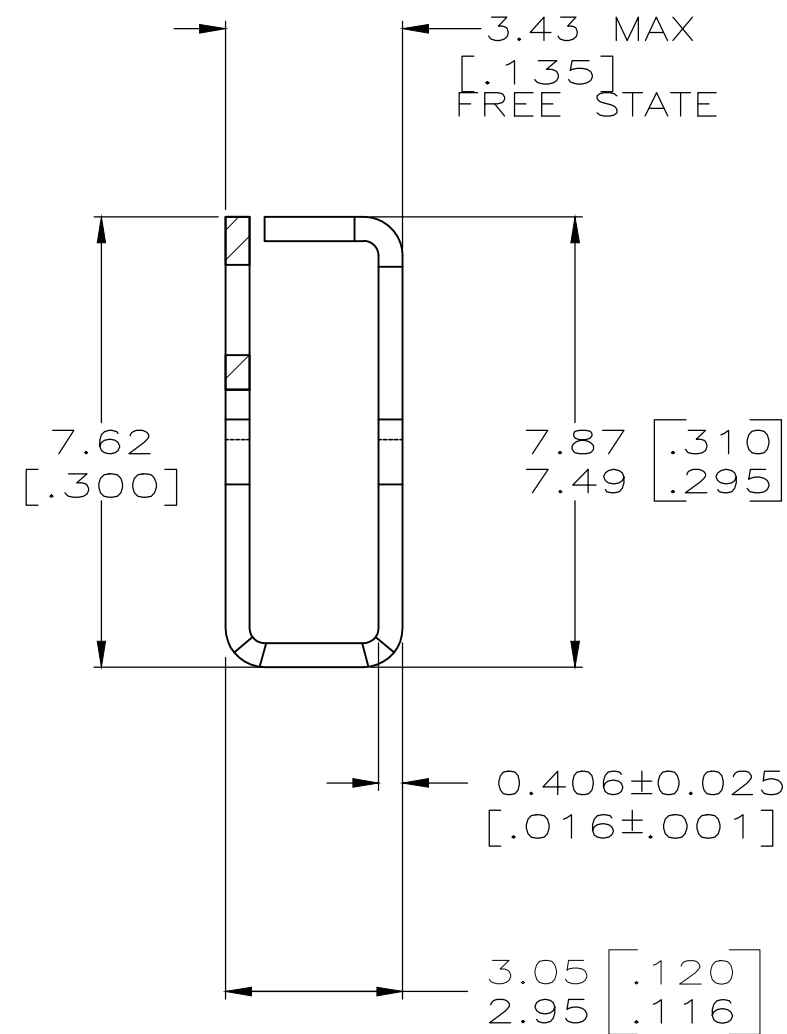
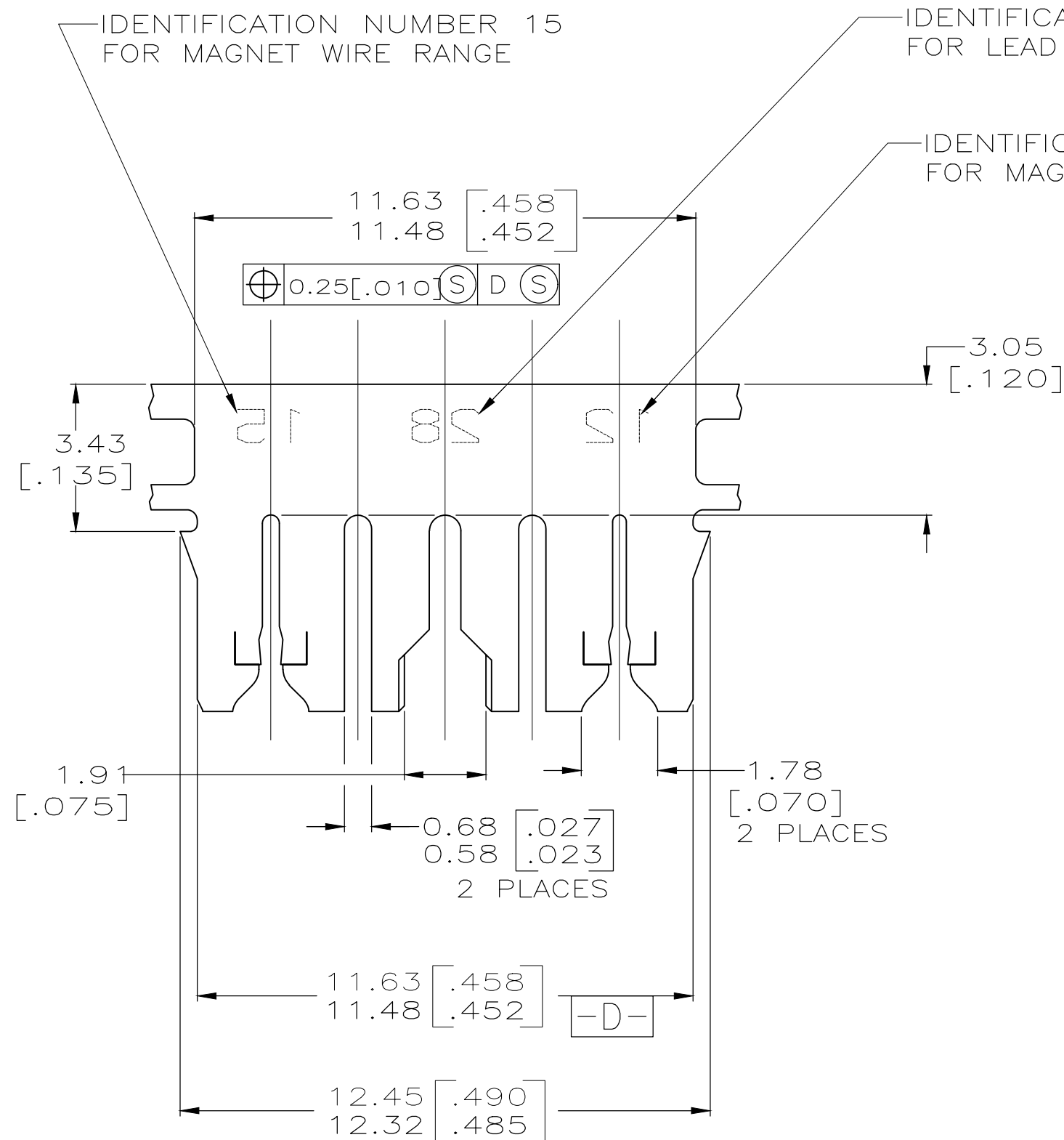
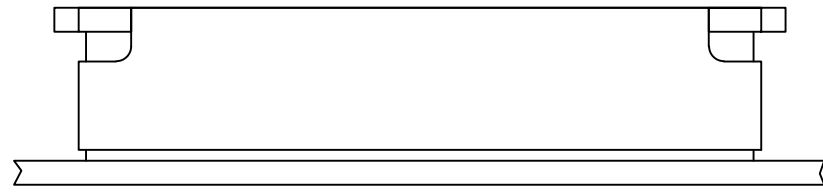

1217209-1

PART NUMBER

THIS DRAWING IS A CONTROLLED DOCUMENT.		DWN MICHAEL S. FEHER 13SEP1999	TE Connectivity	
DIMENSIONS: INCHES		CHK KURT A. RANDOLPH 22SEP1999	NAME	
TOLERANCES UNLESS OTHERWISE SPECIFIED:		APVD KURT A. RANDOLPH 22SEP1999	TERMINAL, SPLICE, TRI-SLOT, 300 SERIES, MTA/MAG-MATE™	
0 PLC ± -	1 PLC ± -	PRODUCT SPEC	SIZE A2	CAGE CODE 00779
2 PLC ± 0.25[.010]	3 PLC ± -	APPLICATION SPEC	DRAWING NO C=1217209	RESTRICTED TO -
4 PLC ± -	ANGLES ± -	96-1039-143	SCALE 8:1	SHEET 1 OF 1
MATERIAL BRASS	FINISH TIN PLATE	WEIGHT	REV C2	
CUSTOMER DRAWING				