

DRAWING MADE IN AMERICAN PROJECTION
 © 1972 BY AMP INCORPORATED. ALL RIGHTS RESERVED. AMP PRODUCTS COVERED BY PATENTS AND/OR PATENTS PENDING.

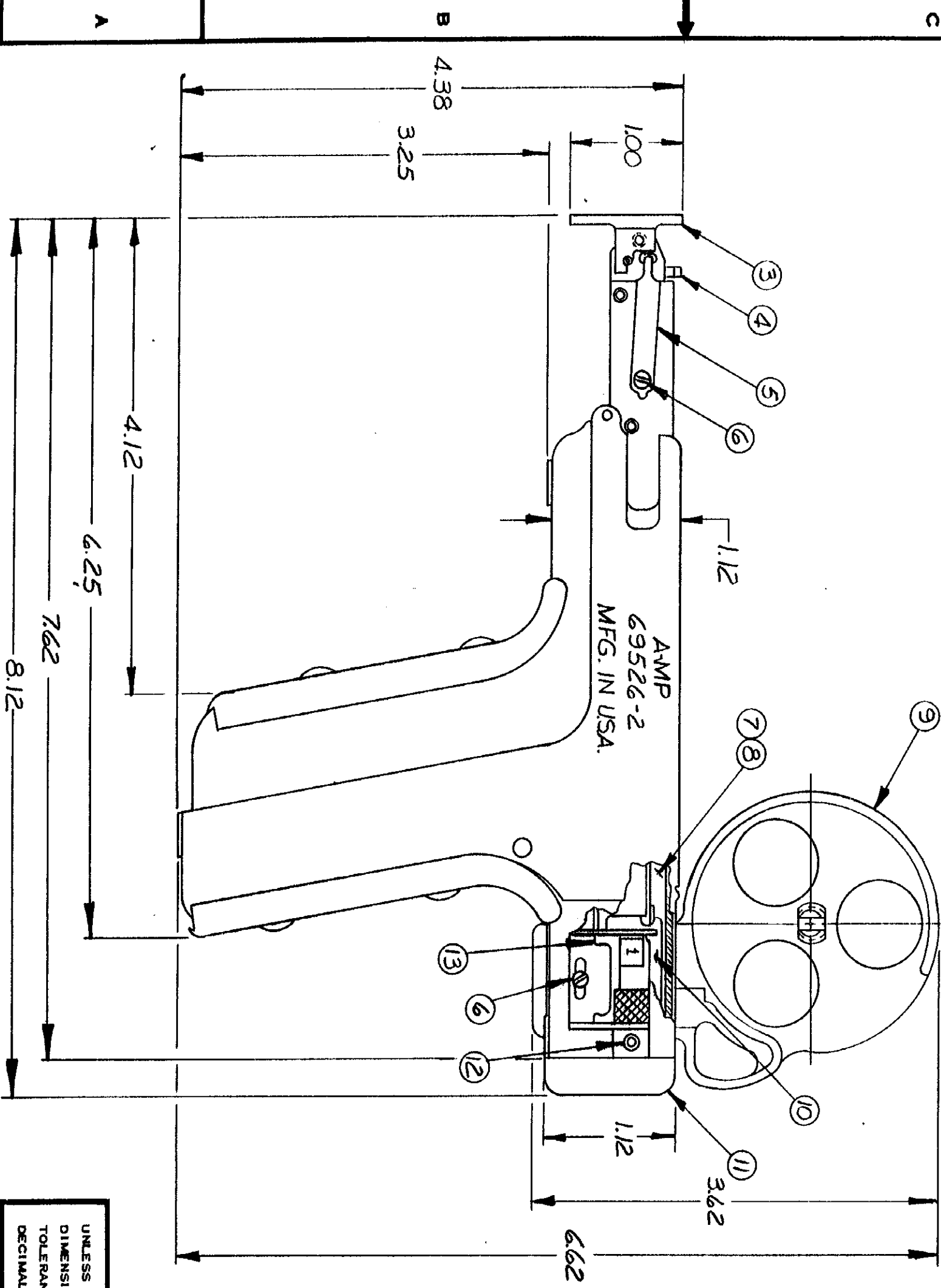
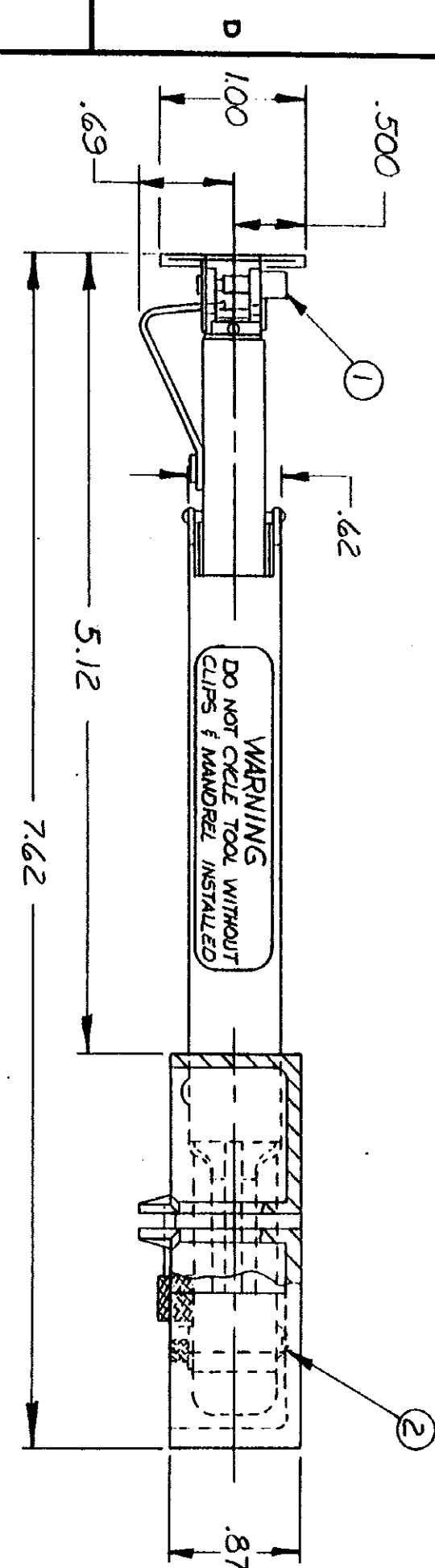

NOTE:
 1. FOR REPLACEMENT OF PARTS OTHER THAN LISTED, TOOL SHOULD BE RETURNED TO OUR FACTORY OR CONTACT FIELD ENGINEERING
 2. * PLATE ASSEMBLY SHOULD BE REPLACED WITH SAME DASH NUMBER TO INSURE PROPER FUNCTIONING OF TOOL.
 3. ALL DIMENSIONS ARE APPROXIMATE.

REVISIONS			
ZONE	LTR	DESCRIPTION	DATE
0		Released on FCN TP 22 57	8-1-72

QTY	PART NO.	DESCRIPTION	UNIT
1	246555-2	DRUM STACKER ASSEMBLY	13
1	240447-1	SCREW, CAP 4-40 X .218 LONG	12
1	241477-2	RAM ROD ASSEMBLY	11
1	241396-3	PLATE ASSEMBLY	10
1	245336-1	REEL HOLDER	9
1	241389	PLATE, PUSH ROD	8
1	241395-2	PUSH ROD ASSEMBLY	7
2	21060-1	SCREW, SELF TAPPING #2 X .12 LONG	6
1	241469	SPRING, INSULATION REMOVING	5
1	8-22140-6	SCREW, SOCKET HEAD CAP	4
1	306535	FOOT, ALIGNMENT	3
1	240419-3	SCREW, 4-40 X .218 LONG	2
1	241135	SCREW, MANDREL MOUNTING	1

UNLESS OTHERWISE SPECIFIED, DIMENSIONS ARE IN INCHES
 TOLERANCES ON:
 DECIMALS ± .015 ANGLES ± 1° 0'

CONTRACT NO. H
 DR. Nancy Raub 8-1-72
 CHK. [Signature] 8-1-72
 APPD. [Signature] 2-1-72
 REL. [Signature]
 OSIN APPD.
 OTHER APPD.

AMP INCORPORATED
 HARRISBURG, PENNSYLVANIA

TERM - POINT
 TOOL ASSEMBLY
 .031 X .062 MANUAL SERVICE

SIZE C
 CODE IDENT. NO. 00779
 NUMBER 69526-2
 SCALE 1:1
 SHEET 1 OF 1

NUMBER 69526-2